

Forte™ Acoustical Shell

General

- Mobile towers and rows of ceiling panels form a full stage acoustic enclosure when placed together on stage.
- Tower and ceiling panels come in various finishes. A choice of paint colors or laminates are available.
- Towers move on a 4" diameter, non-marring casters with adjustable, front leveling capability.
- Towers nest for storage backstage, ceiling panels hang from rigging and are folded and stored in fly-loft.
- Towers and ceilings are constructed from composite, stressed skin panels.
- The stressed skin surface of the composite panels is .188" (5 mm) hardboard on both face and back painted models.
- Tower and ceiling panel framework is constructed of steel.
- Ceiling panel hinges feature self-lubricating bearings for continuously smooth and quiet operation.
- Trim strips on towers and fillers between ceiling panels prevent backstage light from shining between the panels.
- Environmental attributes and LEED compliance for this product can be found at www.wengercorp.com/GREEN or by contacting your Wenger representative.
- Five-year warranty.

Because of the component nature of the Forte Acoustic Shell, different configurations may be created by using different numbers of towers and ceiling panels. For instance, fewer towers can be used to create a smaller shell for chamber music or choral performances.

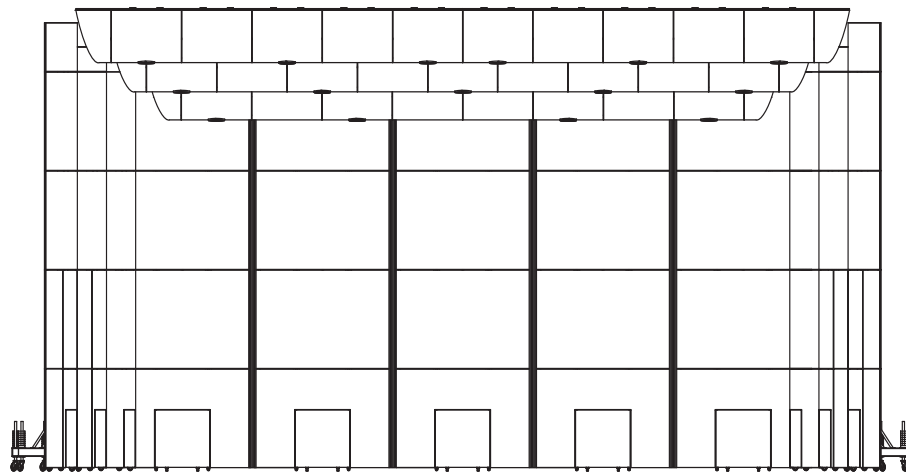

Front View

Performance position.

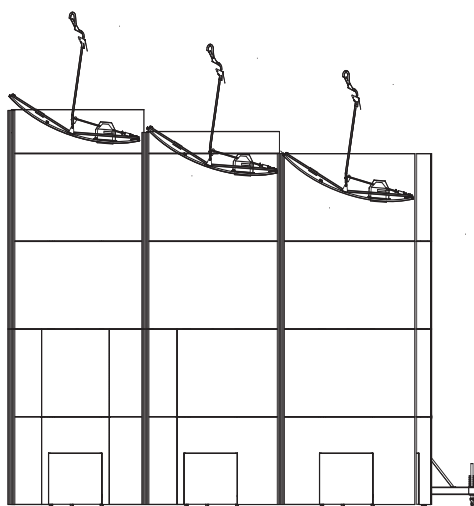

Side View

Full set of towers and ceiling panels used for a full ensemble.

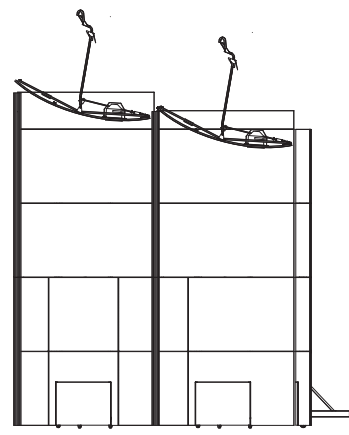

Side View

Fewer towers and ceiling panels used for a smaller ensemble.

Tower

- All towers feature panels with a 10' (3.05 m) radius curve.
- Tower heights are available in one foot increments from 16' (4.88 m) to 20' (6.1 m).
- Doors allow access from stage left or right.
- Framework of towers and base are constructed of steel with a powder coat finish; black.
- Each tower is equipped with a counter-weighted base assembly for stability.
- Each tower incorporates leveling adjustment mechanism.
- Towers nest one within another to minimize storage space.
- The panel faces may be finished with painted hardboard or with a select number of laminates.
- Tower is moved with insertable handle into base frame.
- Five-year warranty.

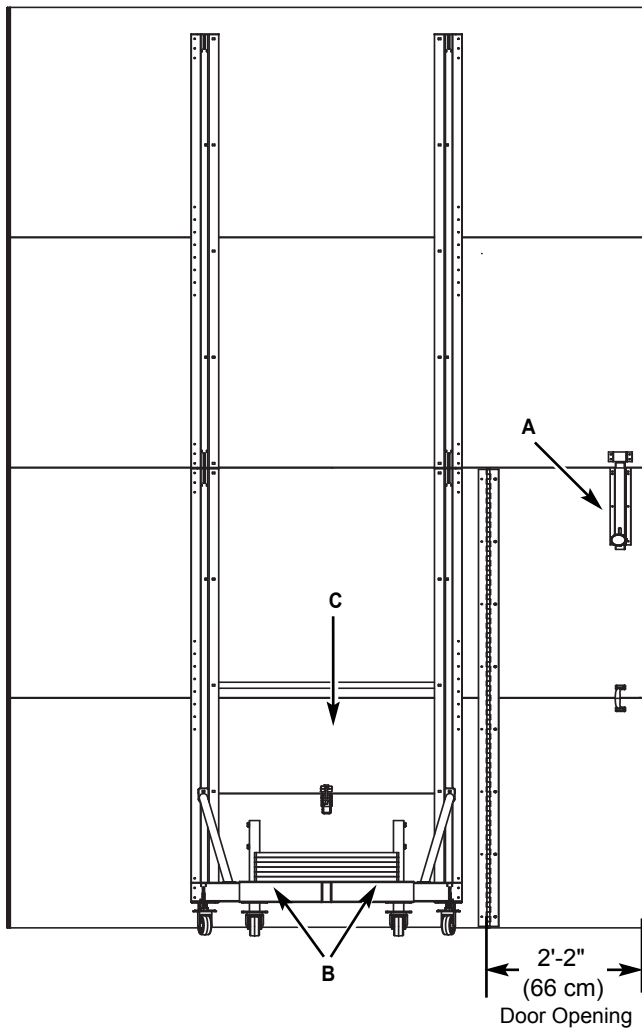

Back View

The door lock (A)

The counter-weighted base (B) provides shell stability when shell is stationary or being moved with handle.

Each tower includes removable filler panel (C) for nesting in storage.

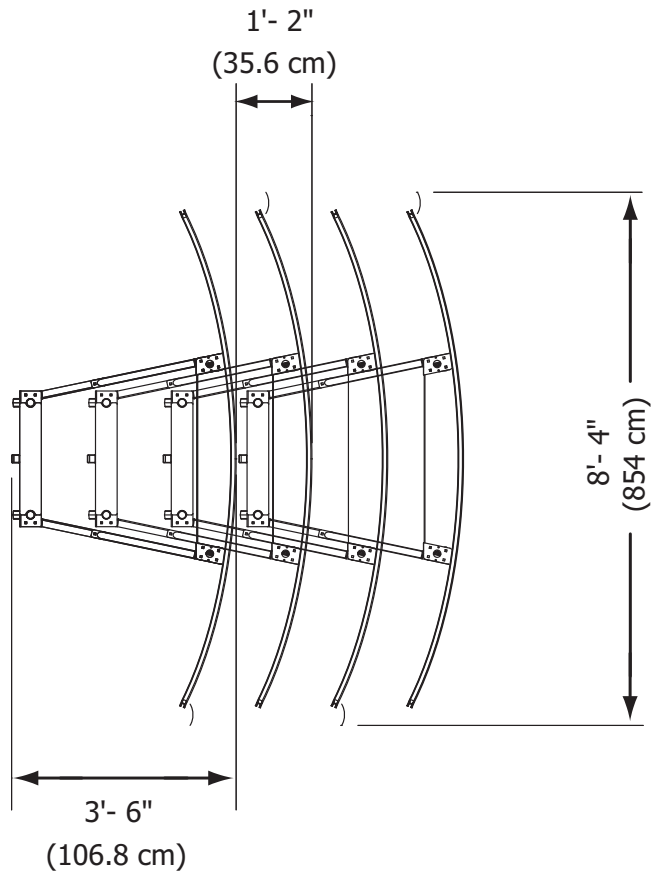

Top View

Showing how Forte Towers nest together in storage position, minimizing required storage space.

Shell Ceiling Panels

- Shell ceiling panels have a 10' (3.05 m) radius curve.
- Ceiling panels store in a vertical position, and rotate to pre-set, adjustable performance angles.
- Ceiling panels are balanced so that each row requires no more than two people to deploy.
- Shell ceiling panels feature an integral steel frame and hang from 2" diameter pipe batten.
- Integral ceiling light fixtures are optional.
- Ceiling storage profile can be as little as 14" (35.6 cm).
- The back side of ceiling panels are painted black.
- Five-year warranty.

Ceiling panels feature the option of integrated light fixtures.

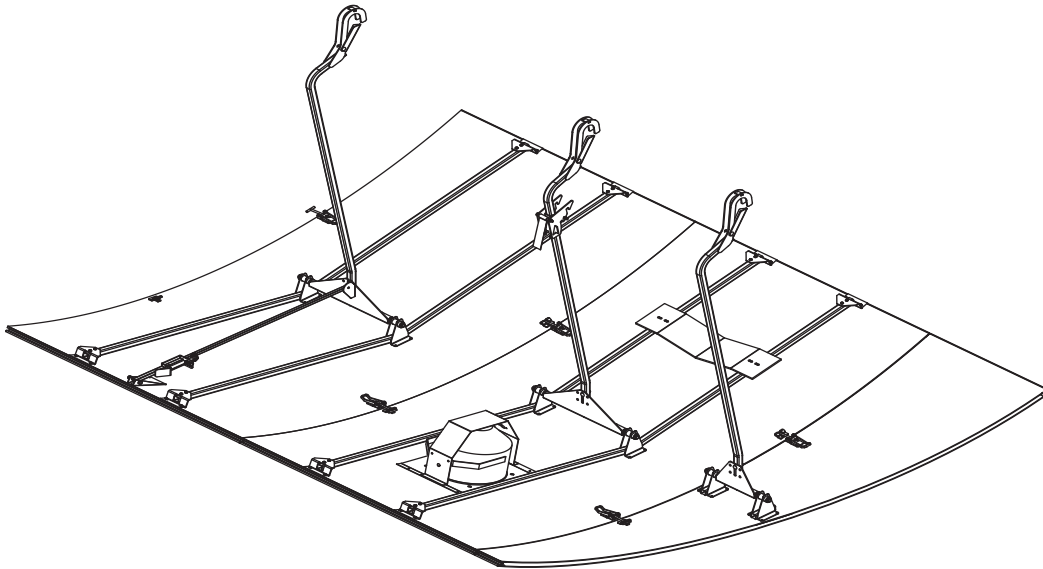

Ceiling panels easily tilt into storage position. Adjustable preset (A) allows shells to rotate back to exact performance angle.

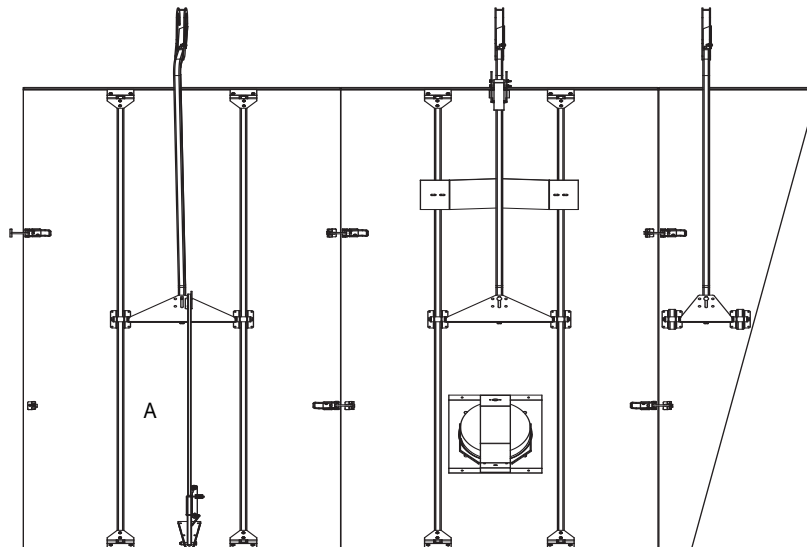

Rear View of a 10' (3.05m) radius ceiling panel.

Optional Ceiling Storage Cart

- Constructed of steel tubing and formed metal components.
- Black baked on finish.
- Four swivel casters with 8" (20 cm) wheels which have a 675 lbs. (306 kg) capacity each.
- Carpeted Deck.
- Foam padding for ceiling face protection.
- Stores maximum of 56' of ceiling or fourteen 4' x 8' (122 cm x 244 cm) sections.
- Overall dimensions 127½" x 61" (318 cm x 155 cm) without ceiling panels.

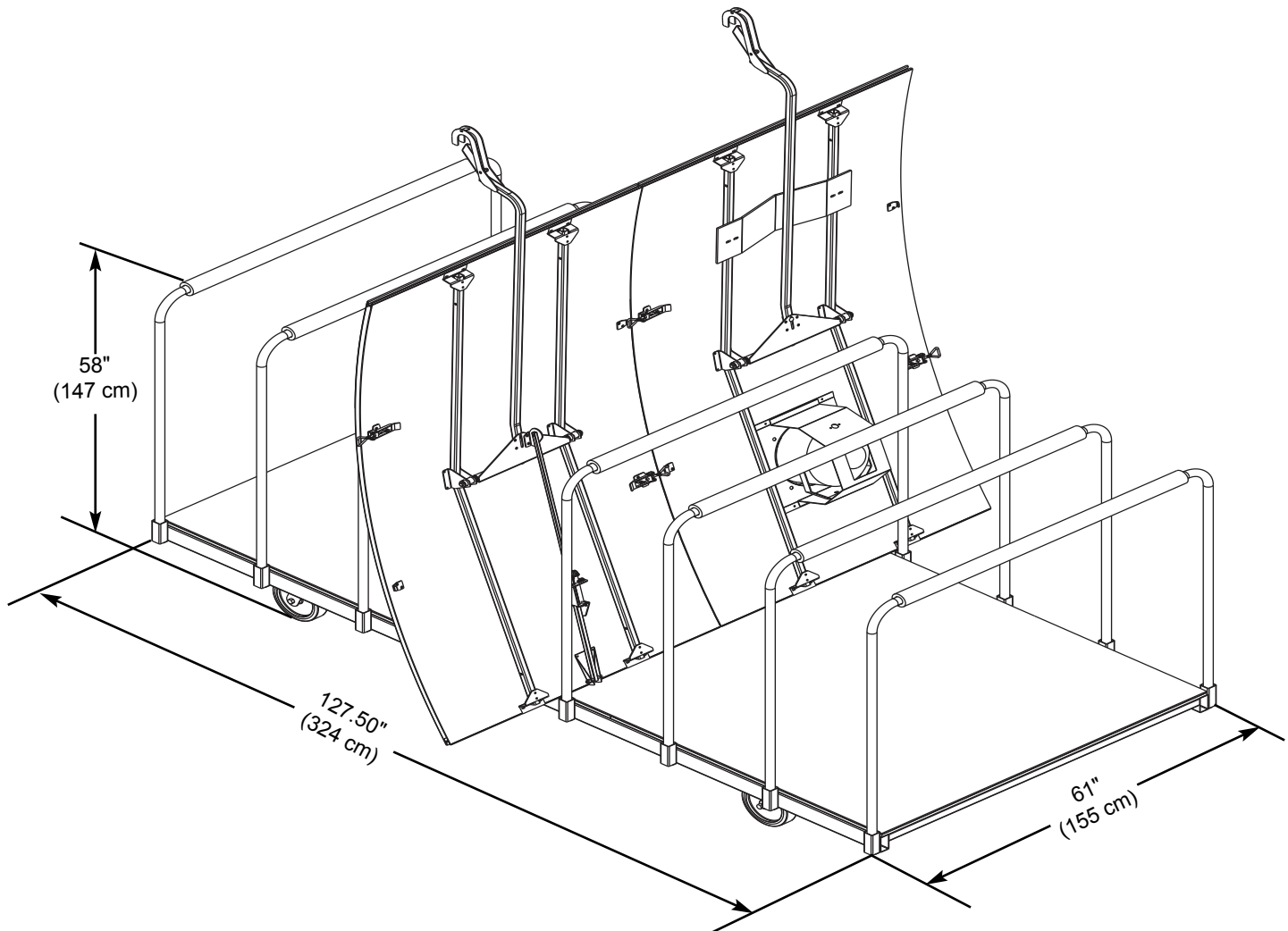

WENGER CORPORATION
555 Park Drive, PO Box 448
Owatonna, MN 55060-0448
Phone 800.4WENGER (493.6437)
Fax 507.455.4258
Customer Service 800.887.7145

WENGER CORPORATION
CANADIAN REPRESENTATIVE OFFICE
Phone 800.268.0148

WORLDWIDE
Phone 507.455.4100
Fax 507.774.8576

WEB SITE
wengercorp.com