

# Diva® Acoustical Shell

## General

- Mobile towers and rows of ceiling panels form a full stage acoustic enclosure when placed together on stage.
- Separate air transporter or wheeled mover easily lifts and moves the towers.
- Towers nest for storage backstage, ceiling panels hang from rigging and are stored in fly-loft.
- Towers and ceilings are constructed from composite, stressed skin panels.
- The stressed skin surface of the composite panels can be a 0.25" (0.64 cm) hardwood veneer plywood, or 0.187" (0.48 cm) masonite with either a painted or plastic laminate finish.
- Tower and ceiling panel framework is constructed of aluminum.
- Door, wing and ceiling panel hinges feature self-lubricating bearings for continuously smooth and quiet operation.
- Tower and ceiling panels come in various finishes. Varnished hardwood veneers, a choice of paint colors or laminates are available.
- Trim strips on towers prevent backstage light from shining between the panels and may be finished in many ways to complement the shell.
- Patented designs.
- Five-year warranty.
- Environmental attributes and LEED compliance for these products can be found at [www.wengercorp.com/GREEN](http://www.wengercorp.com/GREEN) or by contacting your Wenger representative.

Because of the component nature of the Diva Acoustic Shell, different configurations may be created by using different numbers of towers and ceiling panels. For instance, fewer towers and ceiling rows can be used to create a smaller shell for chamber music or choral performances.

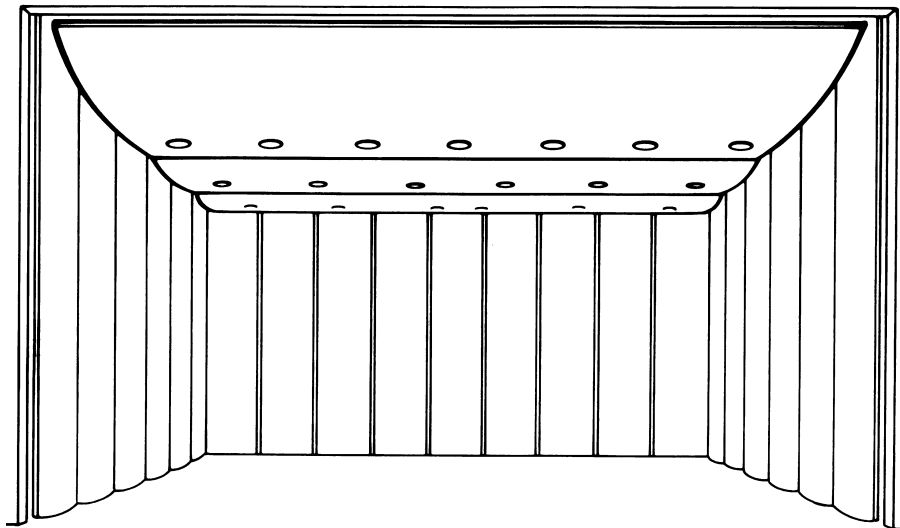

**Front View**

*Performance position.*

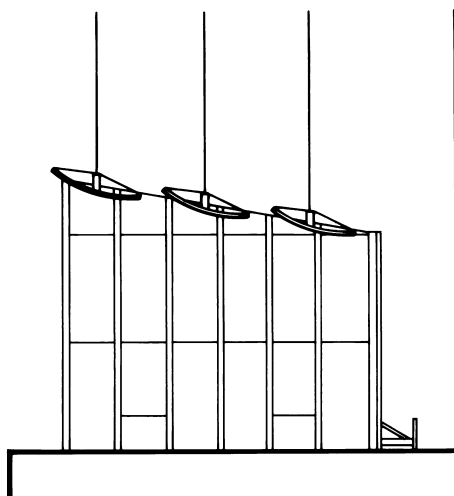

**Side View**

*Full set of towers and ceiling panels used for a full ensemble.*

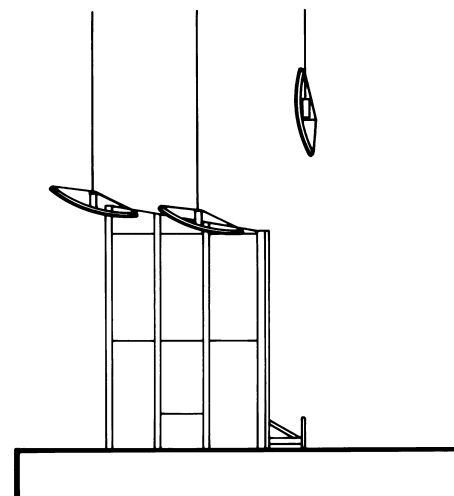

**Side View**

*Fewer towers and ceiling panels used for a smaller ensemble.*

## Tower

- All towers feature panels with a 5' (1.52 m), 10' (3.05 m) or 20' (6.09 m) radius curve.
- Each tower consists of one center panel and two adjustable wing panels.
- Towers are available in heights from 16' (4.88 m) to 32' (9.75 m).  
Custom towers can be as high as 40' (12.19 m)
- Each panel has a lower wing panel that can be used as a door in any location required.
- Double doors allow access of large equipment, including concert grand pianos.
- Framework of towers and base are constructed of aluminum and steel.
- Diagonal bracing distributes weight over several areas of the tower base.
- Each tower is equipped with a counterweighted base assembly for stability.
- A telescoping wing-stay locks tower wings in performance or storage positions.
- Each tower incorporates leveling adjustment mechanisms.
- Towers nest one within another to minimize storage space.
- The panel faces may be finished with varnished hardwood veneer, painted masonite or with a plastic laminate.
- The back side of towers are painted black.
- Five-year warranty.

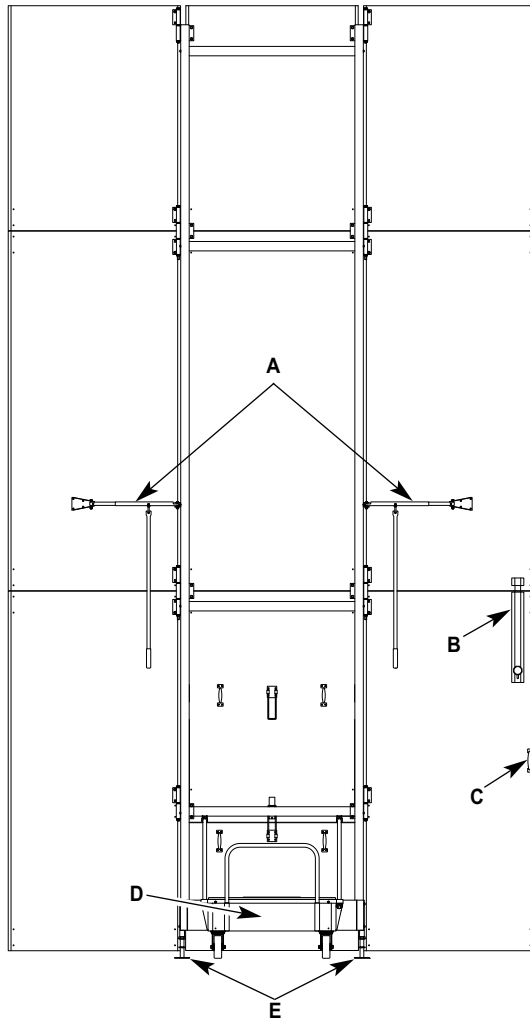

### Back View

Telescoping wing-stays lock wings into performance and storage positions (A).

The door lock (B) and door handle (C).

The counterweighted base (D) provides shell stability when shell is stationary or being moved with Air Transporter.

The shell rests on leveling pads (E) for uniform set-up on uneven floors.

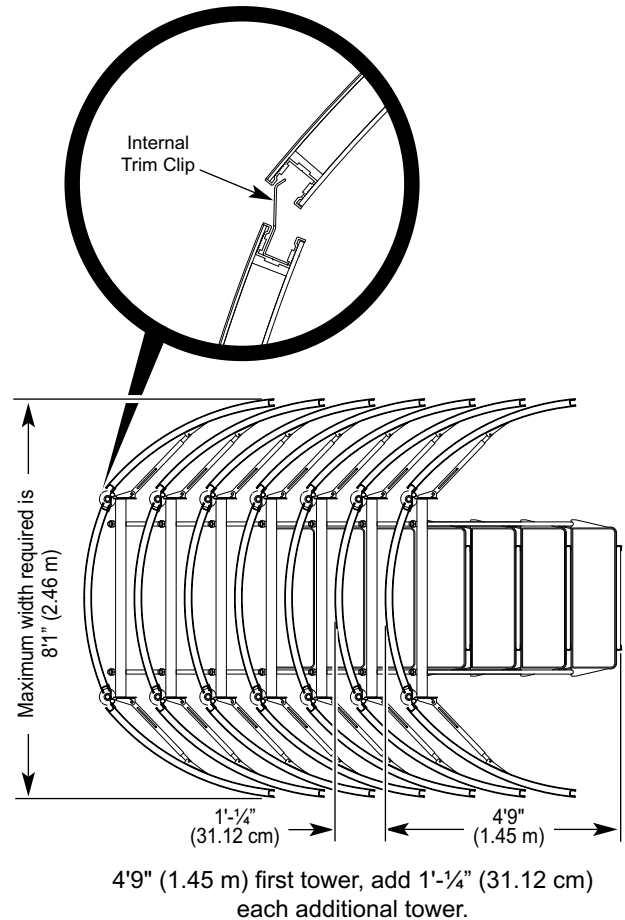

### Top View

Showing how Diva Towers nest together in the storage position, minimizing required storage space.

## Shell Ceiling Panels

- Shell ceiling panels have either 5' (1.52 m), 10' (3.05 m) or 20' (6.09 m) radius curves and are available in various single or triple configurations.
- Panels are designed to hang from theatrical rigging.
- Ceiling panels store in a vertical position, and rotate to pre-set, adjustable performance angles.
- Ceiling panels are balanced so that each row requires no more than two people to deploy.
- Shell ceiling panels feature an integral aluminum alloy truss and hang from stage rigging pipe battens.
- Ceiling panel truss features an integral raceway so separate plug strips are not required.
- Integral ceiling light fixtures are optional.
- Ceiling storage profile can be as little as 13.5" (34.29 cm).
- The back side of ceiling panels are painted black.
- Five-year warranty.

Ceiling panels with built-in truss hang from stage rigging.

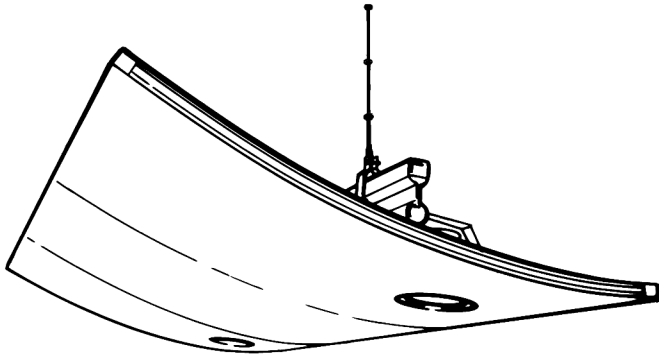

Ceiling panels feature the option of integrated light fixtures.

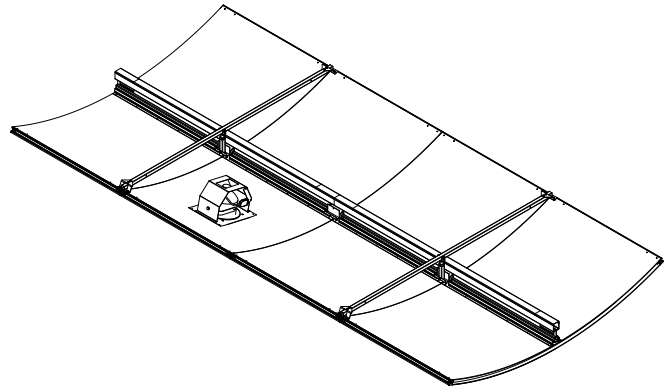

Ceiling panels easily tilt into storage position.  
Adjustable preset (A) allows shells to rotate back to exact performance angle.

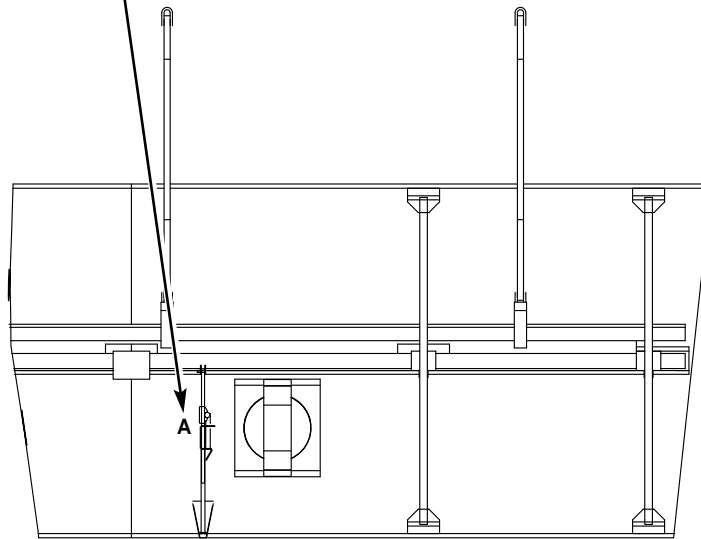

**Rear View of a 10' (3.05m) radius ceiling panel.**

### Air Transporter

- A separate air transport unit makes lifting and transporting the towers an easy job.
- A cushion of air carries most of the tower's weight, which prevents damage to stage floor.
- Moves the tower easily in any direction, so it is easier to position.
- Requires standard 110-volt 15 amp circuit.
- A wheeled mover is also available.
- Five-year warranty.

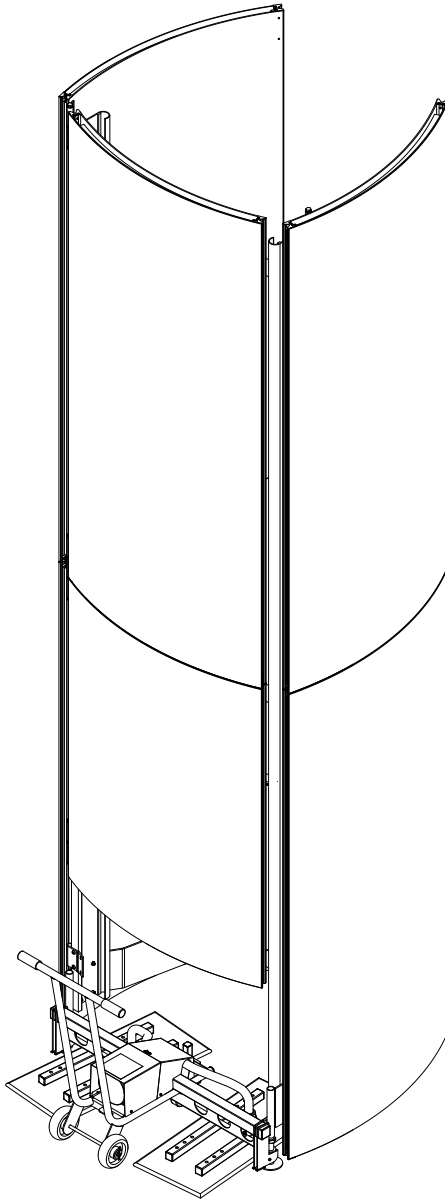

**Air Transporter**

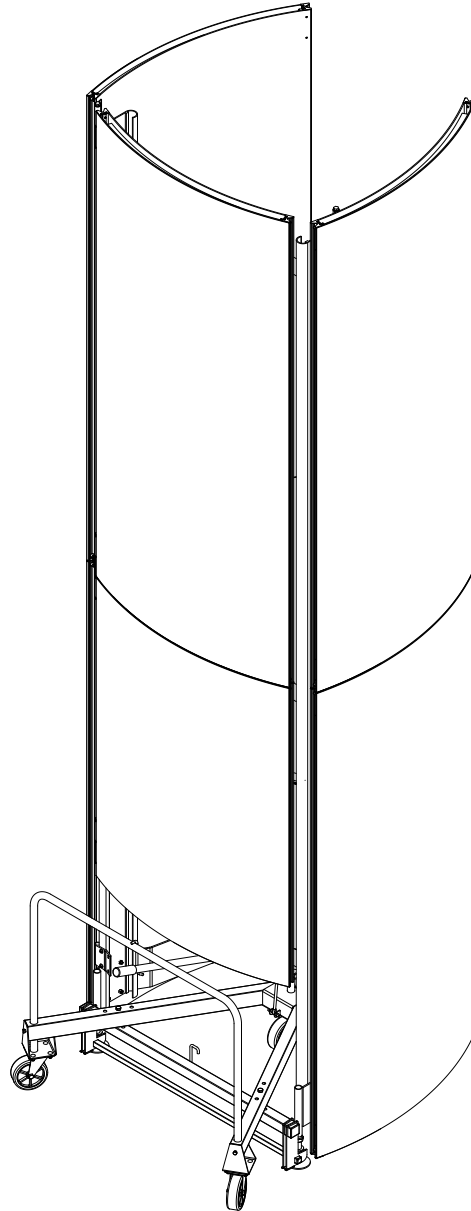

**Wheeled Mover**

Air Transporter lifts majority of the tower weight and maneuvers shell in all directions for exact placements and easy mobility to and from storage.

---

#### WENGER CORPORATION

555 Park Drive, PO Box 448  
Owatonna, MN 55060-0448  
Phone 800.4WENGER (493.6437)  
Fax 507.455.4258  
Customer Service 800.887.7145

#### WENGER CORPORATION

CANADIAN REPRESENTATIVE OFFICE  
Phone 800.268.0148

#### WORLDWIDE

Phone 507.455.4100  
Fax 507.774.8576

#### WEB SITE

wengercorp.com