

CONTENTS

Important User Information	2
General	2
Manufacturer	2
Intended Use	2
Warranty	2
Safety Precautions	3
Required Tools	3
Before Assembly	3
Assembly	3

Note: Please read and understand these Assembly Instructions for the Legacy Classic Acoustical Shell before assembling the parts.

Note: Refer to the illustrations on the following pages. If you need additional information, write or telephone Wenger Corporation at the number below.

IMPORTANT USER INFORMATION

GENERAL

Copyright © 2010 by Wenger Corporation

All rights reserved. No part of the contents of this manual may be reproduced, copied, or transmitted in any form or by any means including graphic, electronic, or mechanical methods or photocopying, recording, or information storage and retrieval systems without the written permission of the publisher, unless it is for the purchaser's personal use.

Printed and bound in the United States of America.

The information in this manual is subject to change without notice and does not represent a commitment on the part of Wenger Corporation. Wenger Corporation does not assume any responsibility for any errors that may appear in this manual.

In no event will Wenger Corporation be liable for technical or editorial omissions made herein, nor for direct, indirect, special, incidental, or consequential damages resulting from the use or defect of this manual.

The information in this document is not intended to cover all possible conditions and situations that might occur. The end user must exercise caution and common sense when assembling or installing Wenger Corporation products. If any questions or problems arise, call Wenger Corporation at 1-800-733-0393.

MANUFACTURER

The Legacy Classic Acoustical Shell is manufactured by:

Wenger Corporation
555 Park Drive
Owatonna, MN 55060
1-507-455-4100 • 1-800-733-0393
www.wengercorp.com

INTENDED USE

- This product is designed to be an acoustical reflector for vocal or instrumental groups. Towers may also be used as a backdrop or as a screen for other functions such as speeches and ceremonies.
- This product is intended for indoor use in normal ambient temperature and humidity conditions.
- This product is intended to be assembled only as described in these instructions.

WARRANTY

The Legacy Classic Acoustical Shell is guaranteed free of defects in materials and workmanship for five full years.

Our guarantee assures you of either a full refund or repair or replacement of the defective materials or workmanship without charge, at the discretion of our Customer Service Department. Just call a Customer Service Representative at 1-800-887-7145 and state the reason you are dissatisfied. If a product return is necessary, your representative will issue a return authorization. This is your sole remedy for breach of this warranty.

Should you have a question or problem with any Wenger product, don't hesitate to call, even if the product is past warranty. It's important to us that all our customers be satisfied.

This is the sole warranty made by Wenger. Wenger disclaims all other warranties, including the warranties of merchantability and fitness for a particular purpose, as well as all liability for incidental, consequential, special, and indirect damage. Wenger liability for direct damages shall be limited to the amount you paid for the product involved. Wenger reserves the right to make product changes without obligation to incorporate such changes into products previously sold.

Some states do not allow the exclusion or limitation of damages or warranties, so the above may not apply to you. This warranty gives you specific legal rights. You may also have other rights which vary from state to state.

SAFETY PRECAUTIONS

Throughout this manual you will find cautions and warnings which are defined as follows.

- **WARNING** means that failure to follow the instruction may result in serious injury or death.
- **CAUTION** means that failure to follow the instruction may result in serious injury or damage to property.

Read all of these safety instructions before setting up the Legacy Acoustical Shell components.

 CAUTION	 CAUTION	 CAUTION
<i>Make sure that anyone working on the Legacy Classic Acoustical Shell has read and understands this manual.</i>	<i>Failure to comply with Warnings and Cautions in this document can result in damage to property or serious injury.</i>	<i>Always observe and comply with the Warnings and Cautions posted on the system equipment.</i>

REQUIRED TOOLS

The following tools are required to assemble the Legacy Classic Acoustical Shell:

- 1/2" Wrench
- 9/16" Wrench
- Cordless Drill with Phillips Head Bit
- Utility Knife (to cut plastic wrap)
- Saw (to cut pallet).

BEFORE ASSEMBLY

Do not remove the crate or Counterweight Assembly until instructed to do so.

Units should be assembled indoors, in a well-lighted space with a level floor. Choose an area close to the performance space - a backstage scene shop is ideal. Make sure units will fit through any doors between the assembly area and the performance space.

It is recommended that two people are used in the assembly process. Assemblers must be strong enough to position the components for assembly.

ASSEMBLY

1. Remove the Hardware Box and check the contents. It should contain the following:

2	Casters with 4" Wheels
8	5/16-18" Hex Nuts
8	5/16-18 x 3/4" Carriage Bolts
10	3/8-16 Hex Nuts
4	3/8-16 x 1" Carriage Bolts
6	3/8-16 x 2-1/4" Carriage Bolts

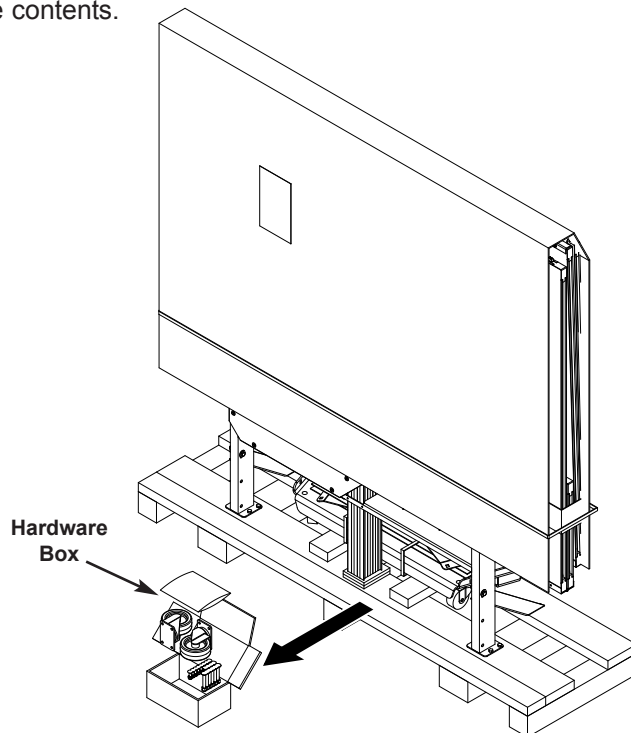

ASSEMBLY CONTINUED

2. Remove and discard the large piece of protective cardboard from the Main Assembly.

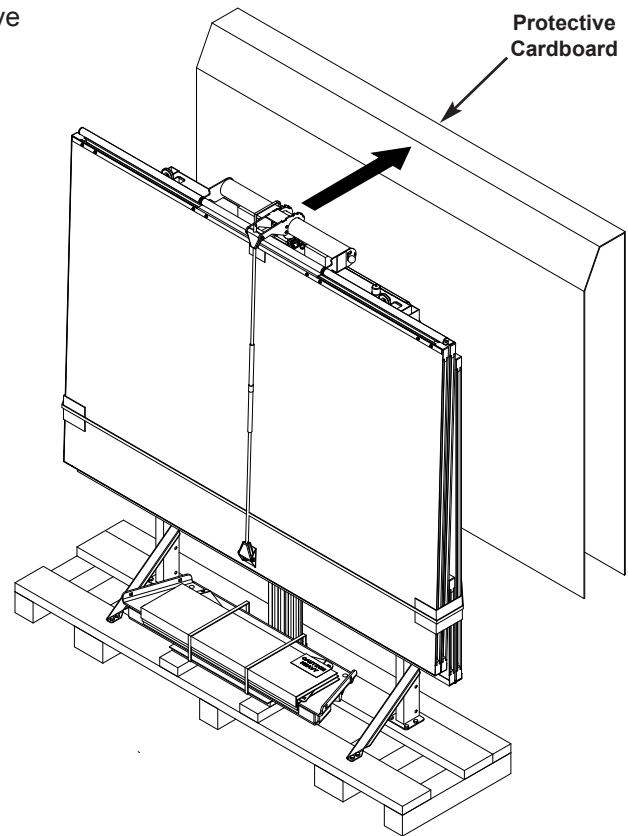

3. Remove and discard the Support Bracket attached to each Frame Upright.
Each Support Bracket is attached to the Frame with a Lag Screw, a Fiber Washer, a Flat Washer and a Lock Nut.

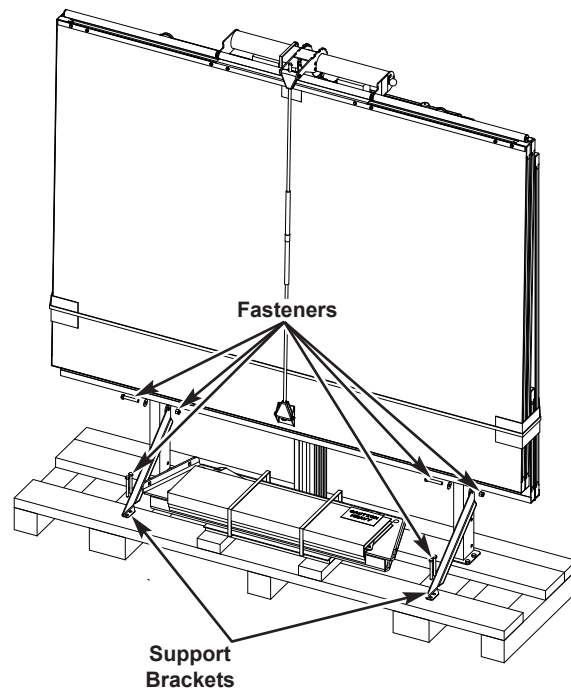

ASSEMBLY CONTINUED

4. Remove the two Side Frames from the Counterweight Assembly by cutting the bands securing them.
Discard the banding and foam padding.

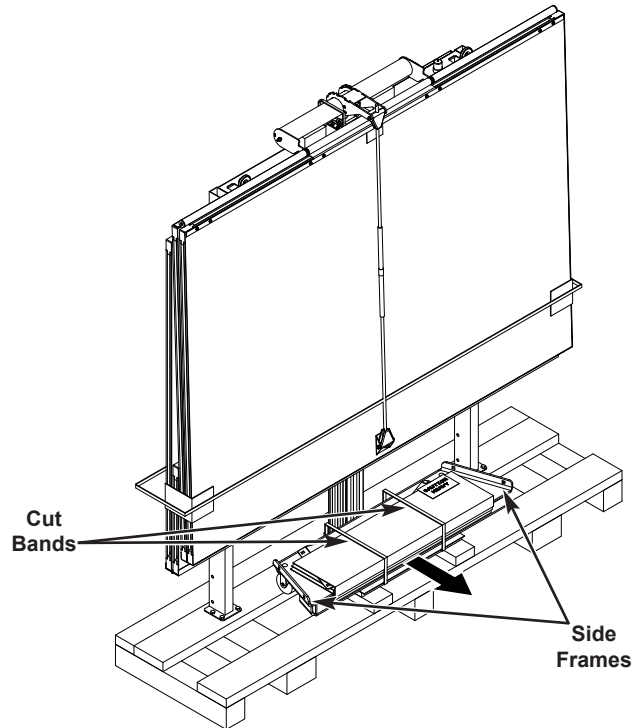

5. Attach the Side Frames to the Counterweight Assembly using two $\frac{3}{8}$ -16 x 1" Carriage Bolts and two $\frac{3}{8}$ -16 Hex Nuts in each.

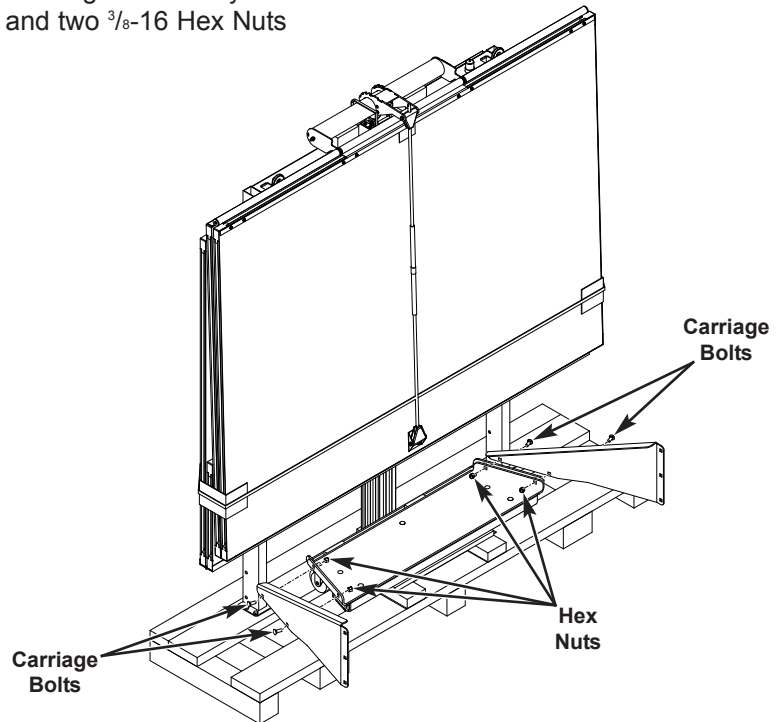

ASSEMBLY CONTINUED

6. Using assistance, lift the Counterweight Assembly off of the crate and down to the floor.



7. Move the Counterweight Assembly to the back side of the shell.
A lift jack may be used if available.

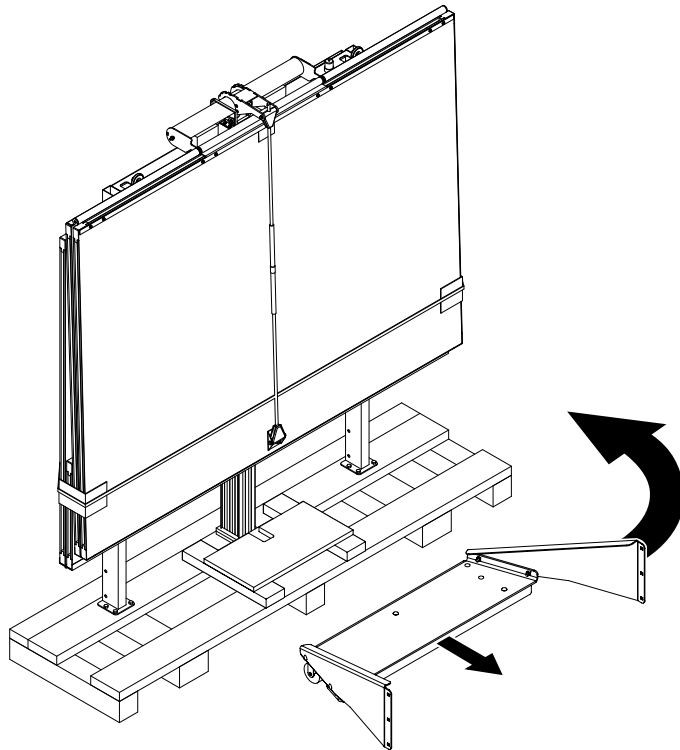

8. Attach the Counterweight Assembly to the Frame using three $\frac{3}{8}$ -16 x 2- $\frac{1}{4}$ " Carriage Bolts and three $\frac{3}{8}$ -16 Hex Nuts on both sides.

NOTE: The Carriage Bolts are to be inserted from the outside of the Frame with the threaded end toward the Counterweight Assembly.

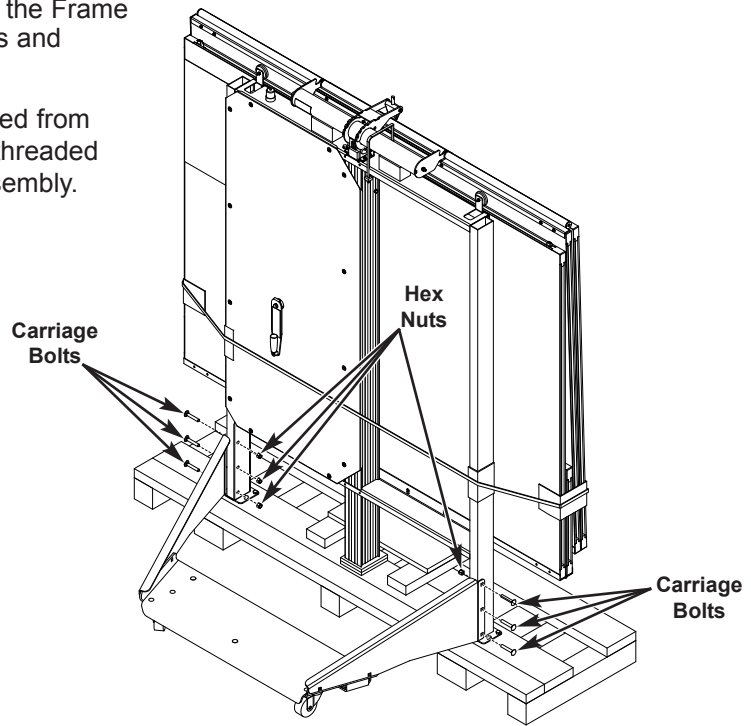

ASSEMBLY CONTINUED

9. Use a saw to make a single cut through the pallet as shown below.
10. Remove the four screws securing the Frame to the cut-away section of the pallet.
11. Remove the cut-away section of the pallet.

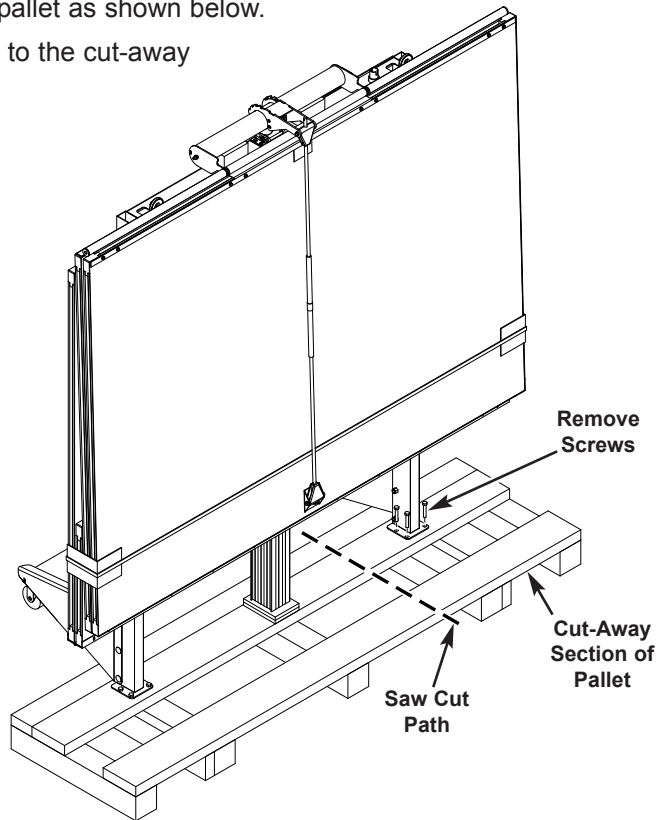

12. Attach a Caster to the Frame as shown using four $\frac{5}{16}$ -18 x $\frac{3}{4}$ " Carriage Bolts and four Hex Nuts.

NOTE: Be sure the Hex Nuts are installed on the underside of the Caster.

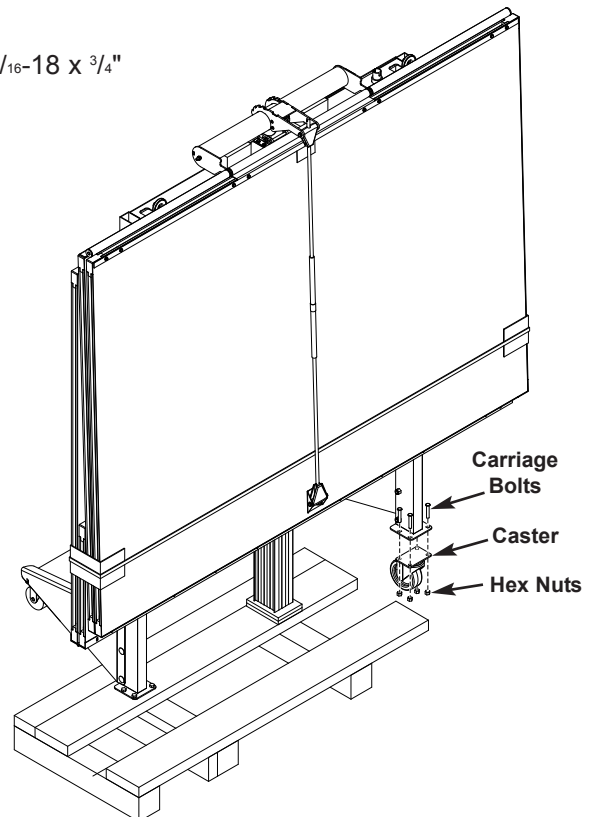

ASSEMBLY CONTINUED

13. Repeat steps #9 through #12 for the other side of the shell.

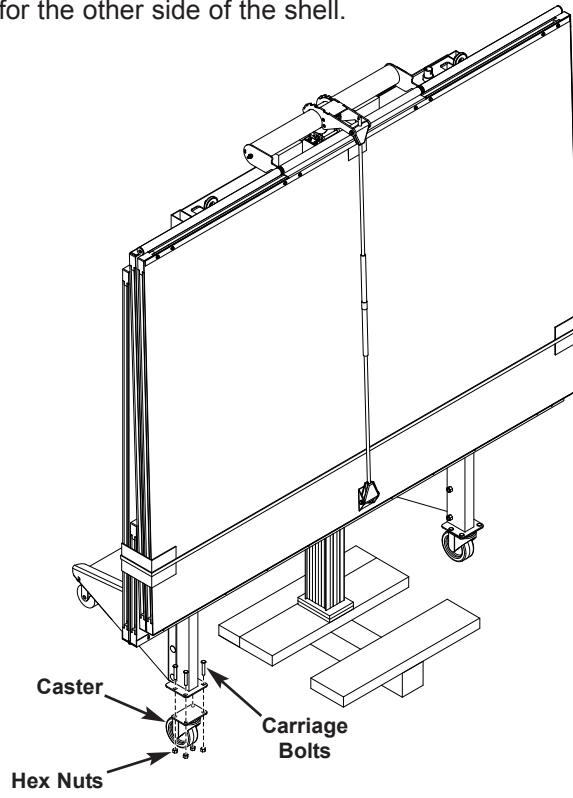

14. Remove the remaining center pallet section.

15. Remove any remaining plastic wrapping, banding, tape or packing.

